

### QCUT 800 A



#### OPERATION

Touch-Screen display for the QATM-Software control is easy to read thanks to smart phone technology and even easier to operate. Compact program sequences are easy to compile and therefore enable automated program sequences. An unlimited number of password-secured program sequences can be updated and backed-up via USB.



The industrial wet cut-off machine Qcut 800 A meets the highest of demands on space available and possibilities for cutting with its innovative concept for design, construction and operation. A water-cooled 30 kW main motor is integrated into the swing arm and the automatic horizontal table (X-axis) and cutting wheel movement (Y-axis) can reach up to 100 mm/sec. through highly dynamic axis drives in rapid-run.

With a totally new approach with the automatic cross-feed movement (Z-axis) through the swing arm, the cutting chamber is ideally put to use.

Parallel setting of the wheel guard during vertical cutting sequences increases the cutting capacity considerably. The large front and hinged door with safety lock enable access to the machine table with longitudinal and cross T-slots. The side door allows easy and convenient change of the cut-off wheel if Z-axis is set on the hard right position.

Recirculating cooling and automatic central lubrication systems are integrated into the robust welded steel construction body of the machine.



#### CONTROL

A wide range of cutting procedures is at your disposal for the very best cutting results. Through the combination of this unlimited range of positions, series cuts or differing cut sequences can be made into reality. The cutting process is rightly supported by controlled cut-off wheel revolutions which can be held constant through an optional wheel measurement facility. Control of the cutting speed and a soft start control serve additionally for an economical cutting feed. Manual control commands in the X-/Z-/Y-axes are also possible using an industrial joystick. The operator console can be slid either to left or the right.

## TYPES OF CUT

Travel and cutting wheel offer a wide-ranging repertoire of types of cut through different combinations. In addition to the linear diagonal cut, the layer and segment-cuts are recommended for gentle cuts. The layer-cut is well-suited for cutting taller and longer objects as well as solid material. The segment-cut is especially suitable for large objects and hard materials.

## MULTI-POSITION-PROCESS MPP

With the “Multi-Position-Process” (MPP) you can place multiple specimens on the table and cut them in one sequence. The teach-in function enables a simple and user-friendly setting of various cutting positions.

## CUT OPTIMIZATION

In addition to the type of cut, variable pulse-cut feed can also be selected. Rhythmic pulsed feed ensures regular cooling and removal of cutting debris from the sample.

## REMOTE MAINTENANCE

Using your existing broadband Internet connection, QATM provides an online fault diagnosis and operator support.

## LASER ALIGNMENT AID

With line laser you can display the scheduled cut on the sample. This helps to define the exact cutting position.



### BASIC MODULE

#### Qcut 800 A

- | automatic table (X-axis) and cutting wheel movement (Y-axis) can reach up to 100 mm/sec. through highly dynamic axis drive in rapid-run
- | automatic cross feed (Z-axis)
- | parallel setting of wheel guard during vertical cutting sequences increases cutting capacity
- | large cutting chamber with large T-slot table
- | machine table made of stainless steel with longitudinal and cross T-slots
- | Multi-position process MPP allows positioning of different components on the table simultaneously and adding into an automatic cutting process
- | easy access to cutting chamber by large sliding and side door (with safety lock during wheel movement)
- | changing of cut-off wheel through side door
- | sliding door with large window made of scratchproof safety glass
- | Touch-Screen display with smart-phone technology and QATM-Software control
- | an unlimited number of password-secured program sequences can be stored and updated; file exchange and backup via USB
- | QATM online-diagnostics and user support available
- | smart phone optics for easy compilation of compact program sequences with position steps and cutting modes (travel-, cut-off-, diagonal-, layer- and segment cut)
- | through the combination of an arbitrary range of cutting positions, series cuts of differing cut-sequences can be made into reality
- | variable pulse-cut feed
- | economical cutting feed by control of the cutting speed and soft start control
- | variable speed
- | manual control of X-/Y-/Z-axis via an industrial joystick
- | incl. cutting wheel arbour with wear ring and optimum chamber illumination
- | automatic central lubrication (6 bar compressed air required)
- | water-cooled 30 kW-main motor integrated into the swivel arm
- | robust welded steel construction body of machine, powder-coated
- | Easy-nut – for easy change of cut-off wheel
- | e-Lab-ready

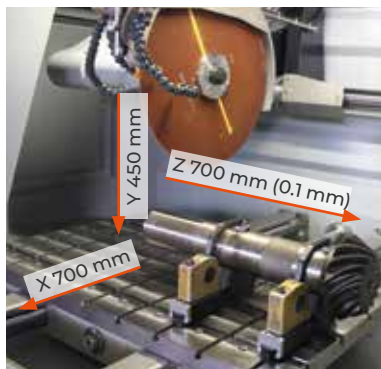

Order No.: M3510000

**EQUIPMENT**
**POWER SUPPLY**
**Equipment 1**

400 V/50 Hz (3Ph/N/PE)

**Order No.: A3510000**
**Equipment 2**

480 V/60 Hz (3Ph/PE)

**Order No.: A3510002**
**WHEEL GUARD**
**Equipment 1**

 Cut-off wheel Ø 610 mm/24"
**Order No.: A3510001**
**Equipment 2**

 Cut-off wheel Ø 813 mm/32"
**auf Anfrage**
**COOLING AND FILTER SYSTEMS**
**Equipment 1**
**Recirculation cooling unit**

- | integrated, mobile
- | multi chamber filtration
- | exchangeable filter fleece, filter performance up to 90% (see consumables)

 Tank ~ 220 ltr.

 Pump ~ 100 ltr./min

 WxHxD 1006 x 528 x 1253 mm

400 V/50 Hz (3Ph/PE)

**Order No.: A3510005**

480 V/60 Hz (3Ph/PE)

**Order No.: A3510006**
**Equipment 2**
**Belt filter system 285**

- | incl. filter roll

 Tank 285 ltr.

 Filter capacity 100 ltr./min (referring emulsion)

 Pump 100 ltr./min

 Filter area 0.85 m<sup>2</sup>

 Filter fleece width 710 mm

 WxHxD 929 x 790 x 1745 mm

 Weight ~ 120 kg

400 V/50 Hz (3Ph/PE)

**Order No.: A6501006**

480 V/60 Hz (3Ph/PE)

**Order No.: A6501007**
**Connection set 285**

- | for belt filter system please order connection set

**Order No.: Z6501007**
**OPTION**
**CENTRIFUGAL SEPARATOR**

- | to remove coolant mist
- | Increases quality of illumination
- | exhauster power 425 or 500 m<sup>3</sup>/h, depends on power supply

400 V/50 Hz (3Ph/PE)

**Order No.: A3510007**

480 V/60 Hz (3Ph/PE)

**Order No.: A3510009**
**ROTATING TOOL**

- | tool with vertical rotary feed, parallel to wheel
- | angle input via software control

**on request**

**OPTION**
**LASER ALIGNMENT AID**

- | laser line to visualize the cutting line
- | laser class 1

**Order No.: A3510004**
**ACCESSORIES**
**BASIC SET QCUT 800 A**
**Order No.: Z3510000**
**SPECIFICATIONS**

Cut-off wheel	1	Ø 610 mm/24" *
	2	Ø 813 mm/32" **
Max. cutting capacity	Ø 225 mm* / Ø 295 mm**	
Arbour size	Ø 32 + 40 mm	
Vertical movement	450 mm	
Horizontal movement	700 mm	
Speed rate	0.001 - 50 mm/sec	
Z-axis automatic	700 mm	
Precision	0.1 mm	
Table WxD	1150 x 800 mm	
T-slot	12 mm	
Motor cut-off wheel	30 kW, S1-mode	
Connected load	50 kVA	
	Variable speed	
Power supply	1	400 V/50 Hz (3Ph/N/PE)
	2	480 480 V/60 Hz (3Ph/PE)
WxHxD	~ 2223 x 2185 x 1860 mm	
Weight	~ 3500 kg (depends on equipment)	

use with cut-off wheel

\* Ø 610 mm or

\*\* Ø 813 mm

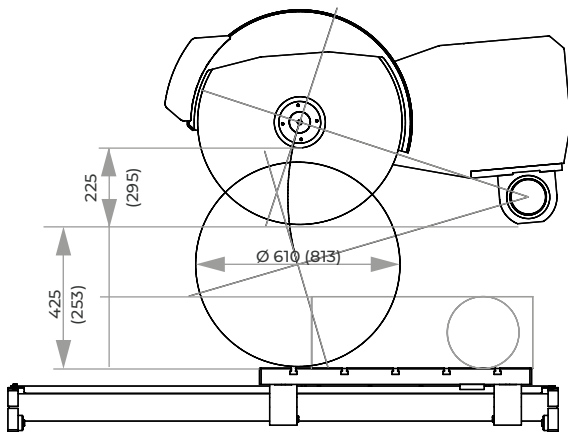

Verfahrenweg X-Achse 700

